



DRAFT

GUIDELINES FOR EARTHQUAKE RESISTANT CONSTRUCTION OF NON-ENGINEERED RURAL AND SUBURBAN MASONRY HOUSES IN CEMENT SAND MORTAR IN EARTHQUAKE AFFECTED AREAS

May 2006



Emergency Architects



UN-Habitat



SUMMARY

1. INTRODUCTION	3
1.1. EARTHQUAKE VULNERABILITY OF PAKISTAN	3
1.2. OBJECTIVE OF THE GUIDELINE.....	3
1.3. EARTHQUAKE DAMAGE TO BUILDINGS	3
1.4. MEASURES FOR ACHIEVING SEISMIC SAFETY	4
2. SITE SELECTION	6
2.1. POTENTIAL HAZARDOUS SITES	6
2.1.1. <i>Steep and unstable slopes</i>	6
2.1.2. <i>Areas susceptible to landslides and rock fall</i>	6
2.1.3. <i>Fill Areas</i>	7
2.1.4. <i>River banks</i>	8
2.1.5. <i>Geological fault and Ruptured areas</i>	8
2.1.6. <i>Forest and trees</i>	8
2.1.7. <i>Close building</i>	8
2.2. SOLUTIONS FOR BUILDINGS NEAR SLOPE	9
2.2.1. <i>Retaining wall</i>	9
2.2.2. <i>Gabion wall</i>	9
2.2.3. <i>Position with the house</i>	10
3. APPROPRIATE PLANNING	12
3.1. REGULAR SHAPE	12
3.2. SHORT WALLS	12
3.3. L-SHAPED BUILDING.....	13
3.4. BOX EFFECT	13
4. CONSTRUCTION WITH SEISMIC CONSIDERATIONS	14
4.1. FOUNDATIONS	14
4.1.1. <i>General</i>	14
4.1.2. <i>Types of Foundations:</i>	14
4.1.3. <i>Plinth masonry</i>	16
4.1.4. <i>Waterproofing and Drainage</i>	16
4.1.5. <i>Mortar</i>	16
4.2. WALLS.....	16
4.2.2. <i>Stones</i>	21
4.2.3. <i>Concrete blocks</i>	23
4.3. OPENINGS.....	24
4.3.1. <i>Openings in wall</i>	24
4.3.2. <i>Lintels</i>	25
4.4. ROOF	25
4.4.1. <i>Typical wooden truss</i>	26
4.5. PLASTERING AND PAINTING	27
4.5.1. <i>General</i>	27
4.5.2. <i>Process</i>	27
5. RETROFITTING	28
5.1. ASSESSMENT OF BUILDING DAMAGE.....	28
5.2. FOUNDATIONS	29
5.2.1. <i>Alternative 1: Cleaning & Drainage</i>	29
5.2.2. <i>Alternative 2: Demolition & Reconstruction</i>	29
5.3. WALLS.....	30
5.3.1. <i>Bricks walls</i>	30
5.3.2. <i>Gable wall</i>	31
5.3.3. <i>Wall corner</i>	32
5.4. ROOF	33

1. INTRODUCTION

1.1. Earthquake Vulnerability of Pakistan

Pakistan is the home to the Hindukush Range of mountains that are prone to earthquakes. Most earthquake zones are located in the North-Eastern part of the country. Depending upon their magnitude some quakes have been felt as far as Northern India and North-central Pakistan.

More recently, a devastating earthquake in the Kashmir valley (October 08, 2005) claimed over 70,000 lives. The earthquake damaged houses and caused landslides which blocked many roads and streams in the epicenter area. The magnitude of the earthquake was 7.6 on Richter scale.

1.2. Objective of the guideline

The objective of these guidelines is to provide the necessary concept and know-how to the communities and local construction workers for earthquake resistant construction of non-engineered rural and suburban houses using locally available materials in earthquake prone regions of Pakistan.

These guidelines are targeting government officials, partner organizations and trainers and may be used as technical reference. It will be the basis of training and capacity building.

1.3. Earthquake Damage to Buildings

During an earthquake the foundation of the building moves with the ground and the superstructure shakes and vibrates in an irregular manner due to inertia of their masses (weights).

As the ground moves, say to the right, the building moves in the opposite direction as if being pushed by an imaginary force. The structure attempts to resist this force and in doing so absorbs the energy released. Weaker construction will provide less resistance and energy absorption and thus result in damage to the structure and in certain cases failure.

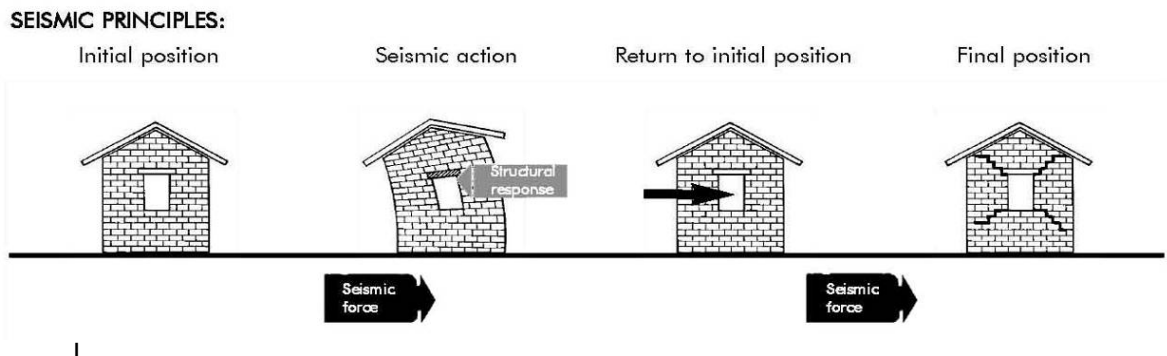

Main causes of failure of a building include, but not limited to, heavy roof, excessive opening in walls, deficient foundations, poor interlocking of walls and poor site conditions.

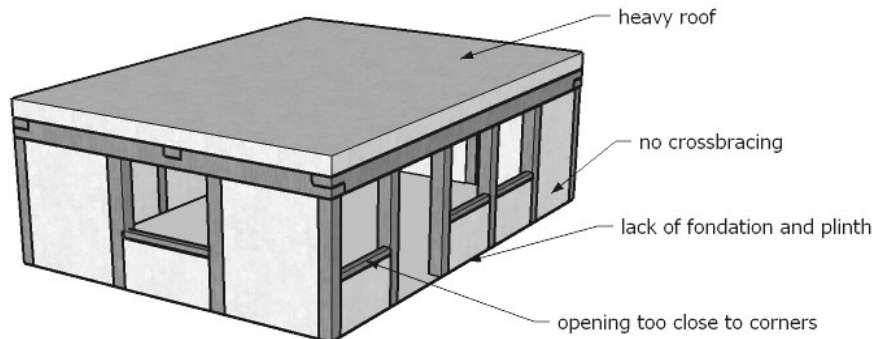

1.4. Measures for Achieving Seismic Safety

? **Proper site selection:** The proper site selection is very important for stable and safe construction.

? **Appropriate planning:** The shape, size and proportion of a building is important for its seismic safety.

? **Good foundation resting on a Firm Base:** The quality of foundation and the surface on which it rests plays an important role in safety of building.

? **The building should act as a single unit for earthquake resistance:** This can be achieved by incorporating following elements in the construction of a building:

- Vertical reinforcement
- Horizontal bands well connected to the vertical reinforcements and embedded in masonry
- Stitching of corners and junctions by steel bars or welded wire mesh.
- Lateral restraints

? **Better bonding within masonry:** The type and quality of bond for the masonry units is the main contributor to the integrity and strength of the walls.

? **Controlled size and location of openings:** Large un-stiffened openings lead to excessive deformation of building during an earthquake. To prevent such effects the opening size and location should be controlled.

? **Light construction:** The light structures suffer lesser earthquake force and hence less damage.

? **Use of appropriate construction materials:** Burnt Brick, Boulder stone, quarry stone, cement mortar, solid block, Concrete blocks, and treated wood.

Taking various considerations into account, a configuration of building suitable in a seismic zone is shown below:

Recommended:

- One floor construction
- Roughly squared room
- Symmetric distribution of Walls
- Small openings
- Use of plaster

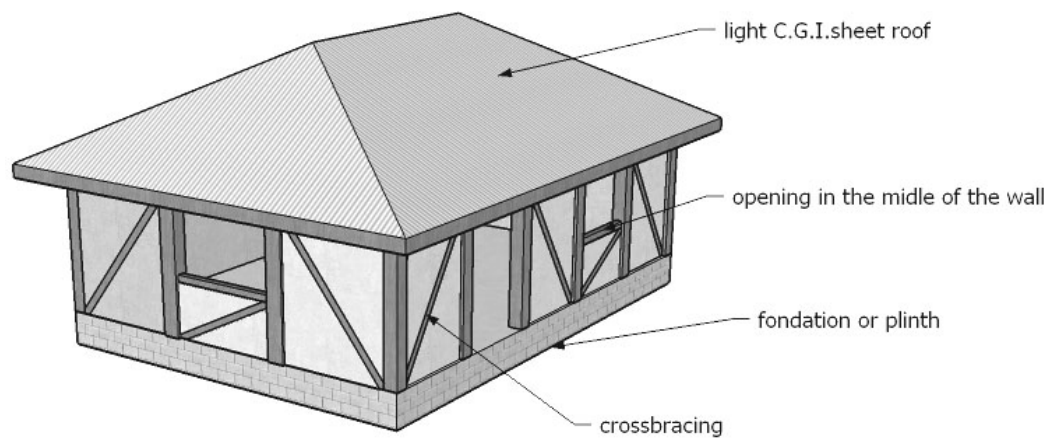

2. SITE SELECTION

The site conditions play a vital role in seismic safety of a building. Hazardous sites should be avoided for building construction to minimize risks against natural disasters. **Site Investigations** will assist in identifying potential danger of sliding, erosion, land subsidence or liquefaction during an earthquake. The local practice of managing any such hazard should be given due considerations. A safer site is the one having

- No danger of landslides
- Sufficient plantation on slope
- Trees not too close to the house
- Mild slope
- Far from river banks

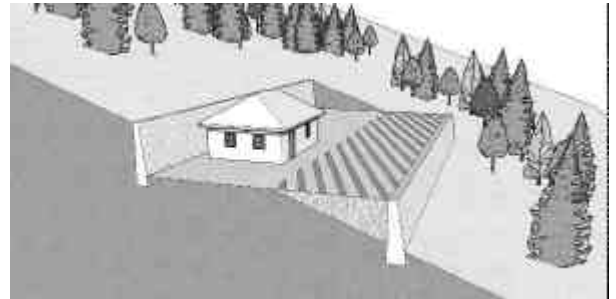

2.1. Potential hazardous sites

2.1.1. Steep and unstable slopes

Building should not be constructed near steep and unstable slopes. Cliffs made of soft or crumbly, clay loam; deposits materials, etc. should be avoided.

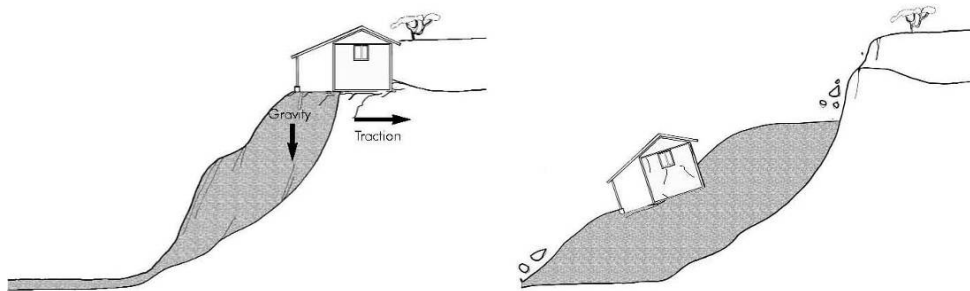

2.1.2. Areas susceptible to landslides and rock fall

Landslides or rock fall areas should be avoided while selecting a site for building construction. Apparently some slopes may look stable, but failure could be triggered by an earthquake. Landslides and rockfall can damage buildings partially or completely. However, building in these areas can be constructed after providing proper retaining walls and green barriers. Simple indication of sustained stability of a slope is the presence of upright standing trees on it. Abnormally inclined trees on a slope indicate instability of the hill slope.

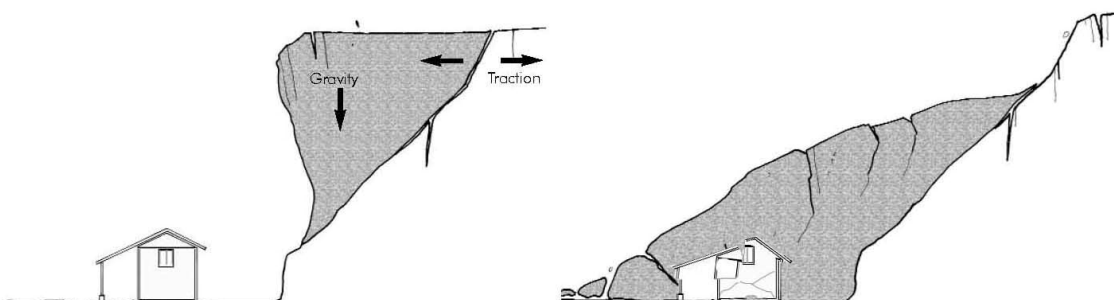

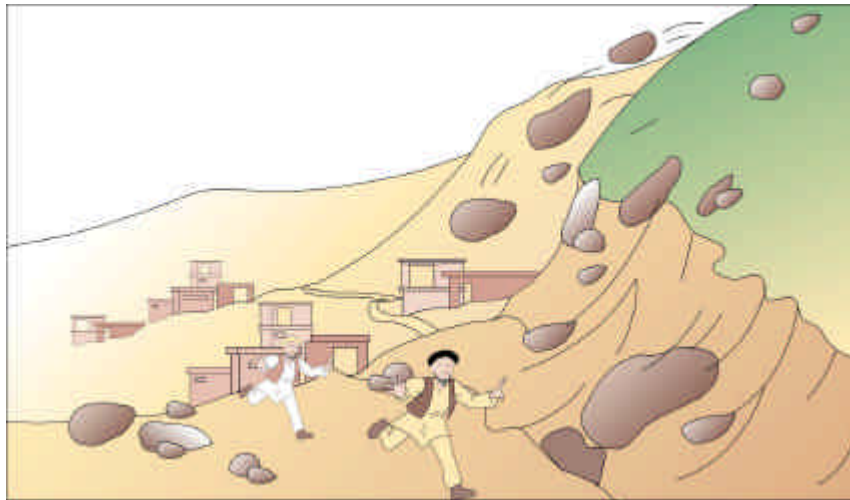

Rock fall area



Instable hill slope

2.1.3. Fill Areas

Building should not be constructed on loose fill. In a filled ground, the bearing capacity of foundation sub-soil is low and settlement of foundation may occur.

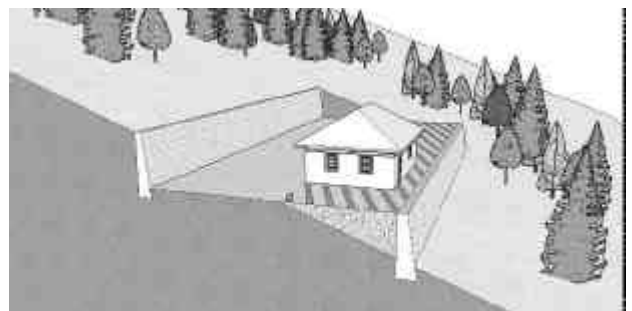

2.1.4. River banks

Buildings should be far enough from the river to avoid flash flood and earthquake damage.

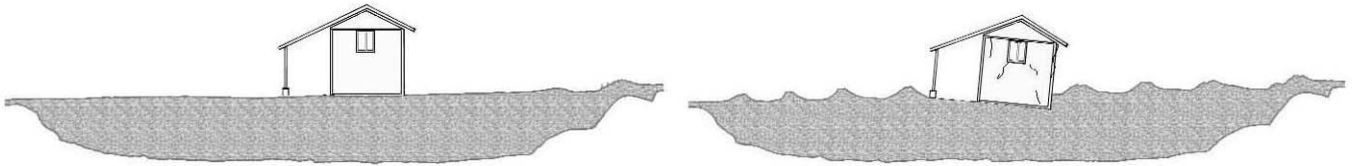

2.1.5. Geological fault and Ruptured areas

Geological fault and ruptured areas that are usually visible, permanent, deep and active should be avoided for construction. Buildings should be constructed at least 250 m away from these lines.

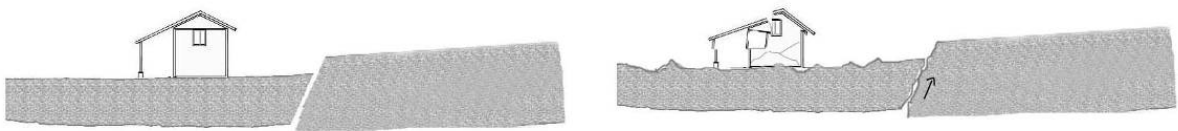

2.1.6. Forest and trees

The forests are really useful to stop landslides but buildings should not be constructed close to any big tree, as there might be a possibility of falling of the trees during earthquake. The distance between tree and house should preferably be at least equal to the height of tree or house, whichever is greater.

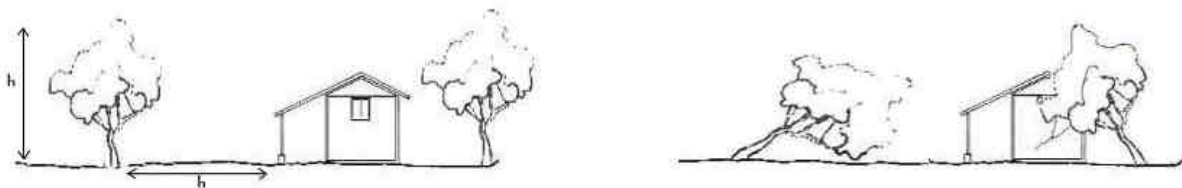

2.1.7. Too Close building

Building should not be constructed close to another building: there might be a possibility of falling of building during earthquake. The distance between two houses should be at least equal to the height of house.



2.2. Solutions for buildings near slope

2.2.1. Retaining wall

Retaining walls can be used to solve problems of limited right of way and confine ground slopes within practical limits and to stabilize steep cut and embankment slopes (but not to stop landslides). The retaining walls may be constructed using reinforced concrete, brick masonry or stone masonry.

2.2.2. Gabion wall

Gabion is a heavy duty, galvanized steel welded wire or twisted wire mesh basket, in the shape of a box, which is divided by wire diaphragms into cells. Filled with heavy material (typically rocks, or broken concrete) that cannot escape through the mesh openings, it is generally used as a construction block, becoming part of a larger unit of several gabions tied together to form a structure. Main features of the gabion as a construction material are:

- Strength
- Permeability
- Flexibility
- Practical Installation
- Durability
- Low Cost
- Aesthetics
- Low Environmental Impact

The wall relies on self weight to resist overturning and sliding due to the lateral stresses of the retained soil.

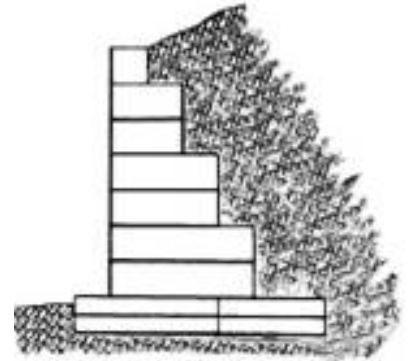

Use pre-cut panels

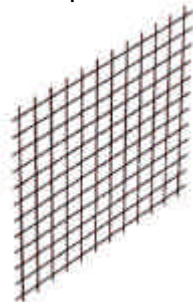

10 SWG galvanized wire mesh (4" x 4")

Ends, diaphragms, front and back panels are placed upright on the bottom section of wire mesh.

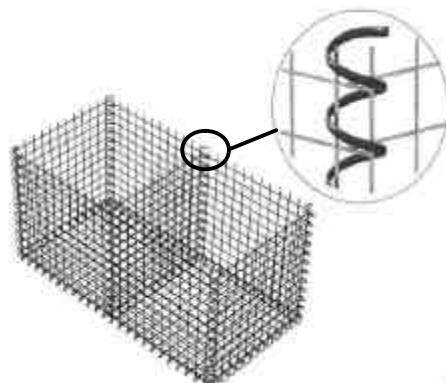
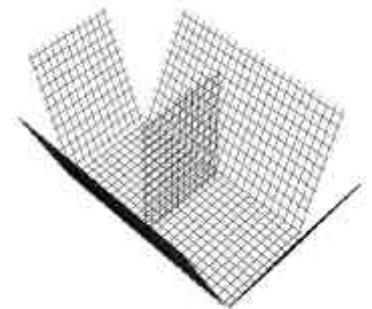

Binding Wire

Secure panels by screwing spiral binders through the mesh openings in adjacent panels.

18" Stiffeners should be placed inside at 12" intervals (4 per cell) and crimped over the line and cross wires on the front and side faces. None are needed in interior cells.

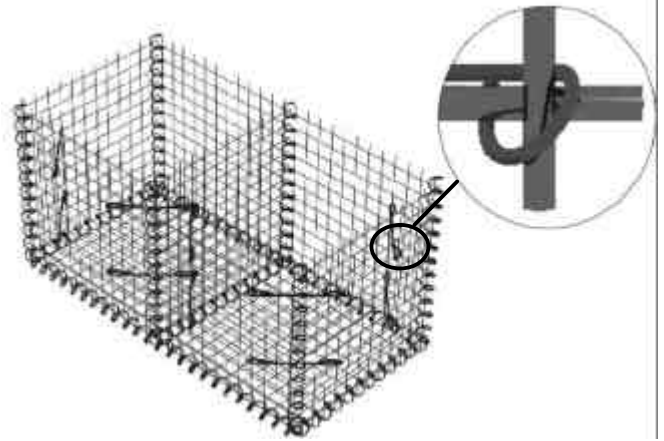

2.2.3. Position with the house

It is necessary to have a safe space between the down stream retaining wall and the house.

DO NOT USE THIS WALL AS A HOUSE WALL. Ideally, the distance (d) should be equal to the height of the retaining wall or house.

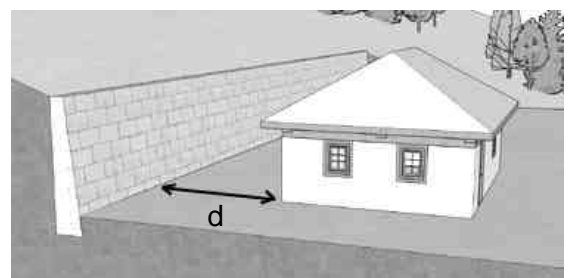

Building should not be constructed on steep slope ground. Building should be far enough from the toe of the slope as shown in the following figure.

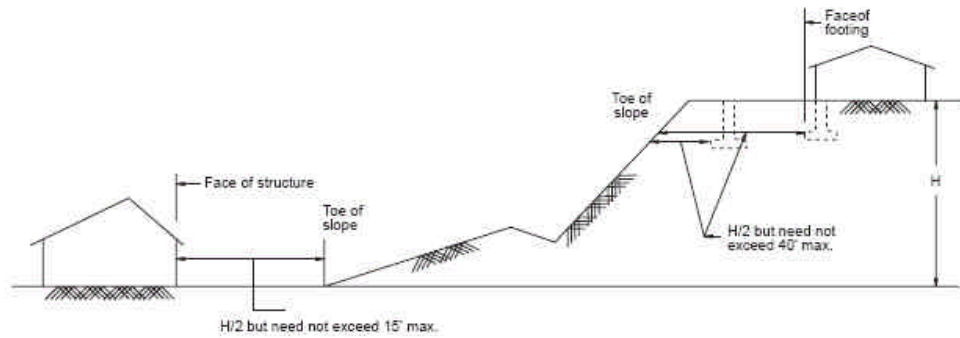

Preparing a site in sloping area

However, whenever it becomes unavoidable to construct a building on a steep sloping ground, stepped strip footing can be used as shown in the figure below. The minimum depth of a foundation measured from the existing ground level on the filled part and from the finished ground level on the cut part, should not be less than 750 mm (2.5 ft). Each step should not be narrower than two times the wall thickness at the base of the superstructure, as shown in figure below.

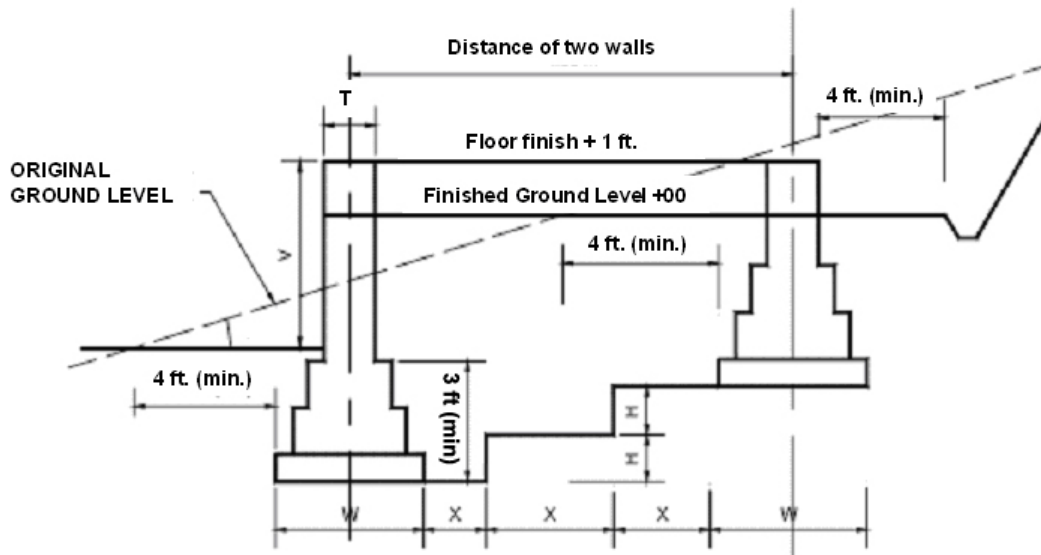

- X = Minimum 2T or 3 ft whichever is more
- H = Not more than 1 ft.
- V = Not more than 3 ft. without provision of retaining wall
- T = Thickness of wall

Foundations at different levels in sloping area

3. APPROPRIATE PLANNING

The shape, size and layout of the building is important for its seismic safety. Constructions with Asymmetrical plan and elevation are more vulnerable to earthquake than those having symmetrical plans elevations.

3.1. Regular shape

Regular shaped buildings like square, rectangular, or circular resist the earthquakes more effectively as compared to irregular buildings and are therefore preferable in earthquake prone areas. During the earthquake movements the **corners** of non-uniform buildings are stressed more and may be damaged. Complex shaped buildings, shall therefore be made simple by providing gaps at appropriate locations. Some complex shapes and their simplified solutions are shown:

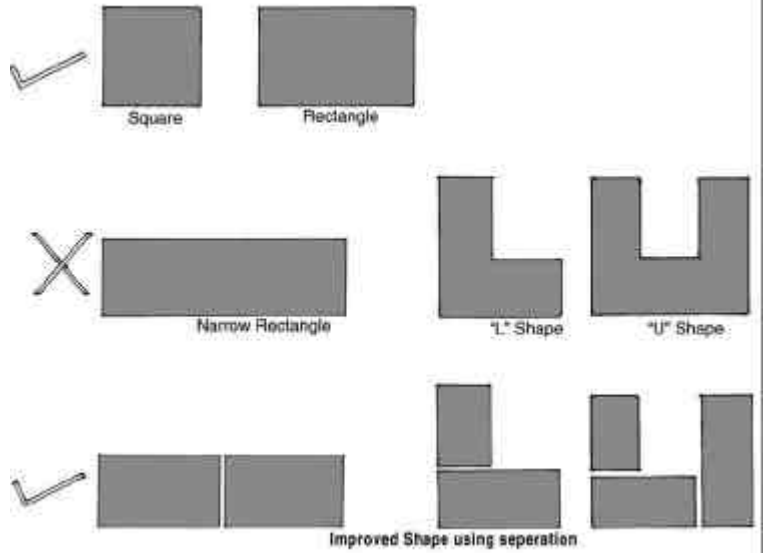

3.2. Short walls

In long and narrow buildings, longer wall is weak against earthquake forces and can easily fall down during an earthquake. Therefore, if long and narrow buildings are constructed, they should be divided into two or more blocks with sufficient gap between them. The individual length of separate blocks should not exceed three times its width. The foundation of these blocks may be connected to each other and separation can be made only in the superstructure. The other alternatives include provision of cross walls and buttresses as shown below.

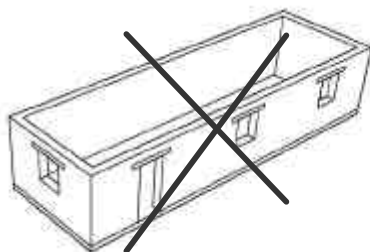

Not recommended

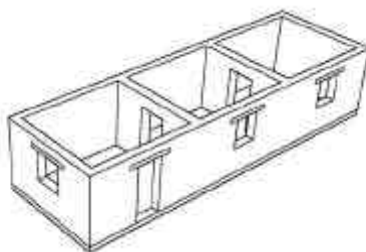

Recommended

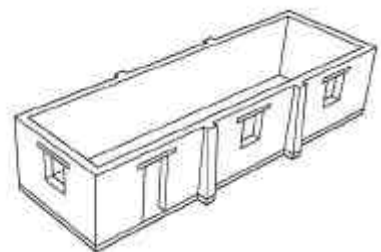

3.3. L-shaped building

'L' shaped buildings are irregular and inappropriate. However, small projection can be allowed, if the projection is less than one-sixth of the width of the building. Alternatively the building may be subdivided using gaps at critical locations as illustrated in section 3.1

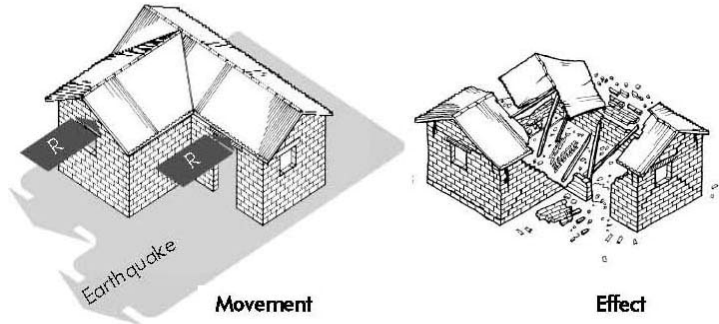

3.4. Box Effect

One of the essential principles of earthquake-resistant construction is to use a compact, box-type layout. Furthermore, all the components of the building such as walls, floor and roof structure, should be well tied up with each other, so the building could act as a box during earthquake vibration. The maximum length of wall between cross walls shall preferably be limited to 15 ft for an effective box action.

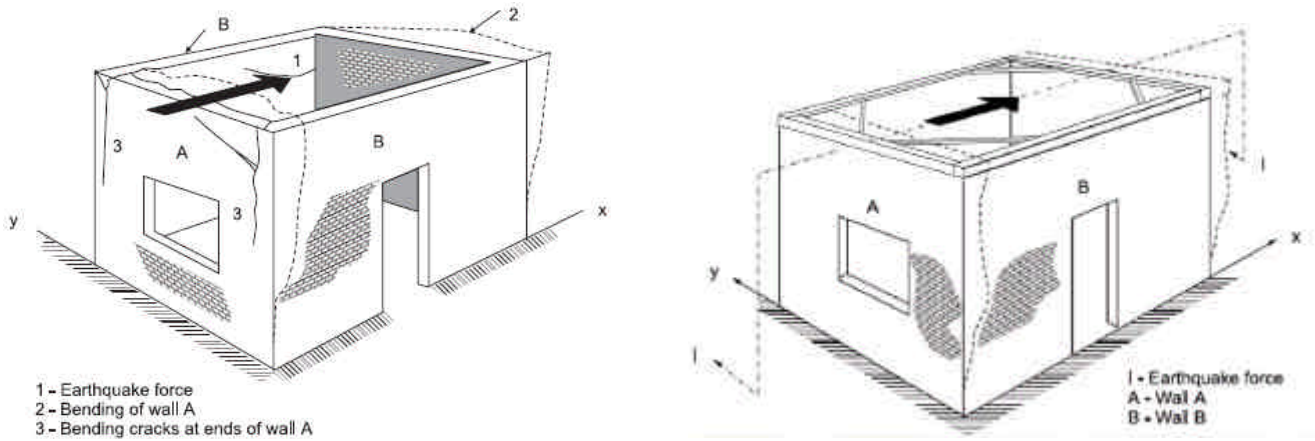

4. CONSTRUCTION WITH SEISMIC CONSIDERATIONS

4.1. Foundations

4.1.1. General

Foundation of a building is the part of the building below the ground level. The purpose of the foundations is to transfer the load of the construction to the ground. The weight of the structure must be suited to the load capacity of the ground which in turn shall be stable. The structure must also be correctly joined and anchored to the foundations. Generally stepped strip footing should be adopted for load bearing wall construction.

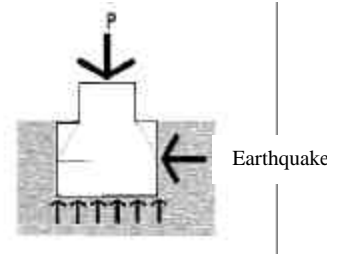

Width of foundation: The width of foundation should be sufficient so that soil is able to bear the weight of the building without excessive settlement. If the foundation soil is soft, the width of foundation should be more. Similarly, if the building weight is more, the foundation should have a greater width. A minimum width of 2'-6" is suggested for single storey construction.

Materials of foundation: Mud or mud bricks are not strong enough to resist earthquake forces at the foundation level. It is recommended that the foundation should be preferably built by using dressed stones, burnt clay bricks or concrete blocks. A 3" to 6" thick pad of lean concrete shall be provided under the foundation. The concrete mix proportions for this pad shall be 1:4:8 (one part cement, four parts sand and eight parts crushed aggregates)

Depth of foundation: The depth of foundation below existing ground level should be at least 3'-0" for soft soil. For Rocky ground the depth of footing may be reduced to about 1'-6".

4.1.2. Types of Foundations:

The following figures present suggested foundation details for stone masonry, brick masonry and concrete block masonry load bearing walls for single storey construction. For double storey construction the width shall be increased by one foot. The depth of foundation shall be reduced for rocky grounds.

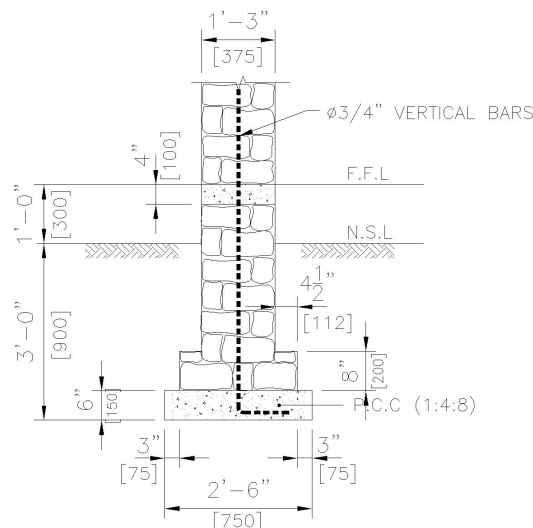

Stone Masonry Foundation

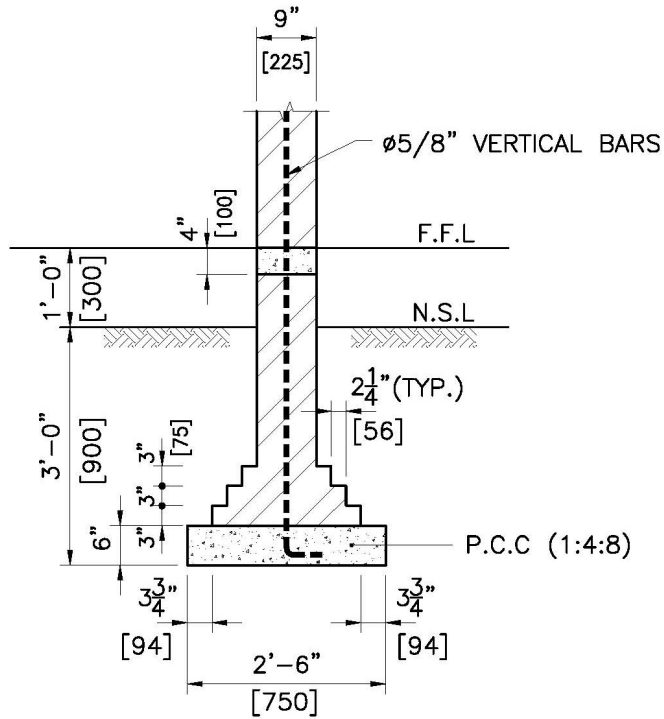

Brick Masonry Foundation

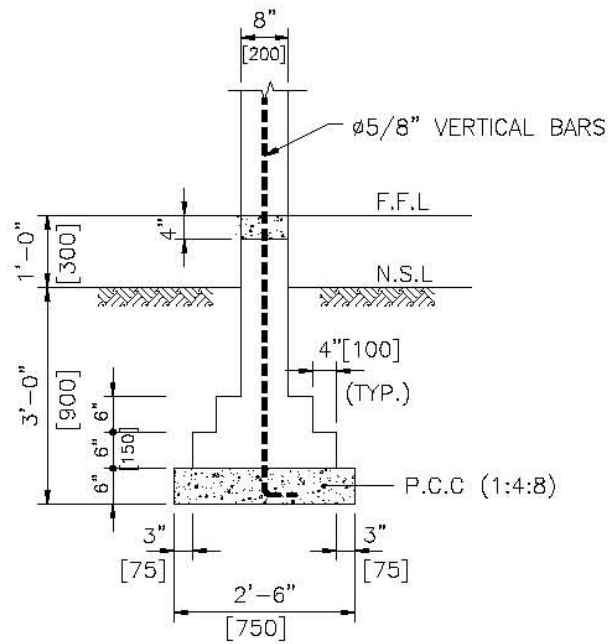

Concrete Block Masonry Foundation

- In case of loose soil, provide some nominal reinforcement in foundation bed concrete.
- If stone soling is used under foundation reduce the thickness of foundation strip to 3".
- The vertical steel bars indicated in the foundations are to be provided at corners and junction of walls as explained in the later sections.

4.1.3. Plinth masonry

Recommended construction: The plinth masonry should preferably be constructed using stone or burnt bricks laid in cement mortar. Cement mortar or lime mortar is stronger than mud mortar in binding the stones or bricks in the wall together to resist earthquake forces.

Height of plinth: The height of the plinth should be above the flood water line or a minimum of 300 mm (1 ft) above ground level. Wherever possible the height of plinth shall not be more than 2'-6". Where higher plinths are required the thickness of walls below plinth shall be increased.

4.1.4. Waterproofing and Drainage

Why waterproofing layer: Water makes the foundation soil weak. In an area that experiences rainfall or snowfall, it is recommended to use a waterproofing layer at the plinth level before starting the construction of wall above the plinth and provide an apron and drain around the house to prevent runoff water that might wet walls or enter the foundation.

4.1.5. Mortar

Type	Proportion of Material	
	Cement	Sand
Masonry Wall	1	4
Plaster	1	6



Use concrete & mortar within 45 minutes of mixing. Use water as less as possible

4.2. Walls

Although a lot of wall construction materials are available, however, one goal of this guideline is to promote local materials:

- Concrete
- blocks/bricks/dressed stones
- Brick that are over burnt, under burnt and deformed shall not be used.
- Quarry stones that are solid with no obvious fractures shall be used.
- Boulder stone shall never be used in its natural shape. These boulders should be dressed or semi-dressed before they are laid. Small boulder stones up to 6" may be used by casting them in the shape of large concrete block.
- Solid block (concrete or stone) shall be of regular shape, preferably free from broken edges, any type of deformation and cracks. Normal acceptable mix is 1:3:6 (cement: sand: 10 mm down coarse aggregates). Curing of these units for a minimum of seven days shall be done.

4.2.1.1. Manner to place the bricks

BONDING SIMPLE WALLS

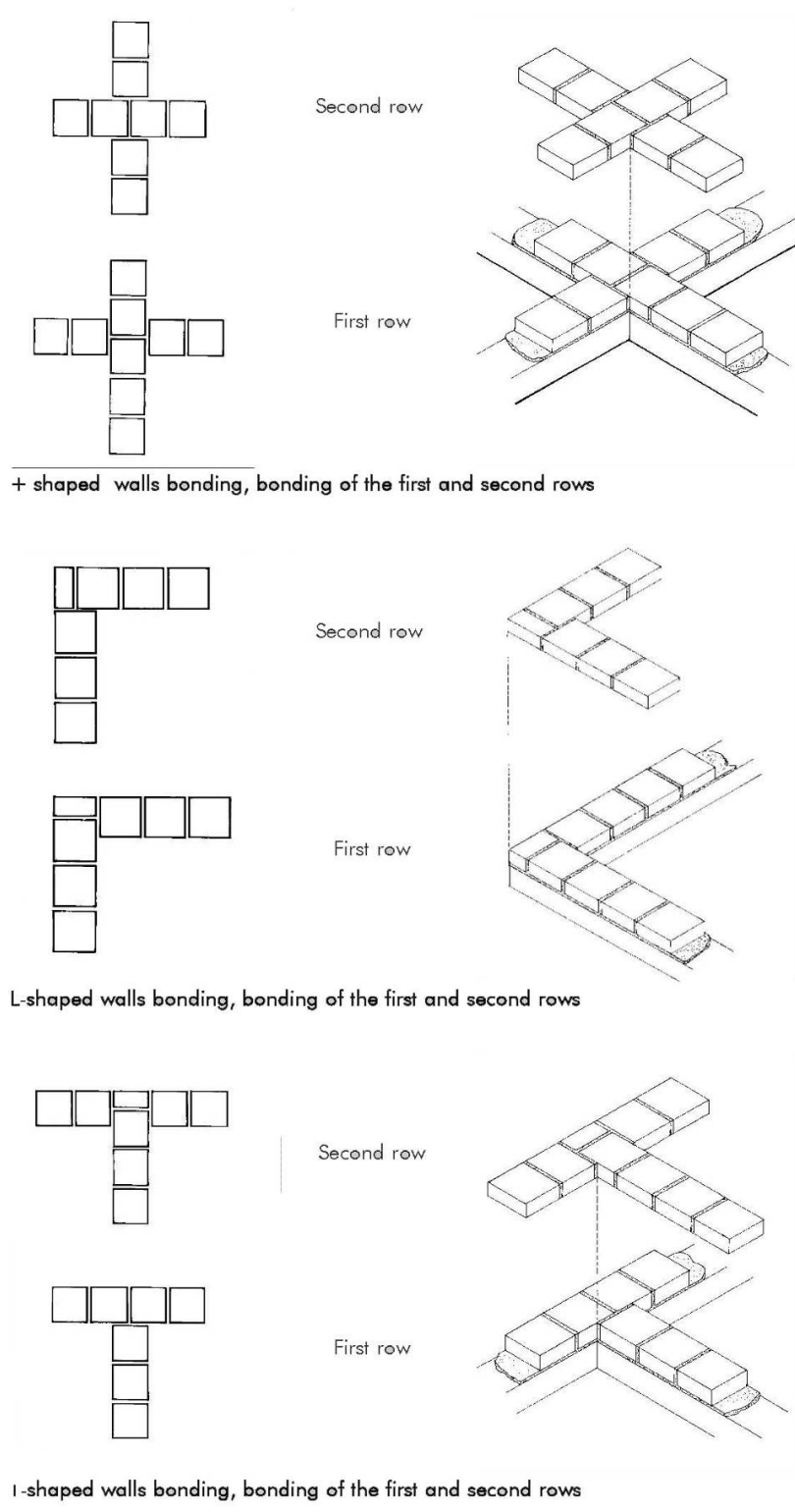

Bonding of reinforced walls shall be as per details of section 4.2.1.4

4.2.1.2. Joints

- All joints should be raked and faces of wall cleaned at the end of each days work
- On faces to be plastered, joints shall be raked to 20 mm depth.
- Vertical joints of consecutive course should not come directly over one another.
- Mortar joints shall have uniform thickness and should not exceed 6mm (1/4") and should be fully filled with mortar.
- Brick must be lightly mortared on side before laying.
- Dry or butt joints shall not be used or made.

4.2.1.3. Factors to be considered while making the building on Load bearing brick wall system

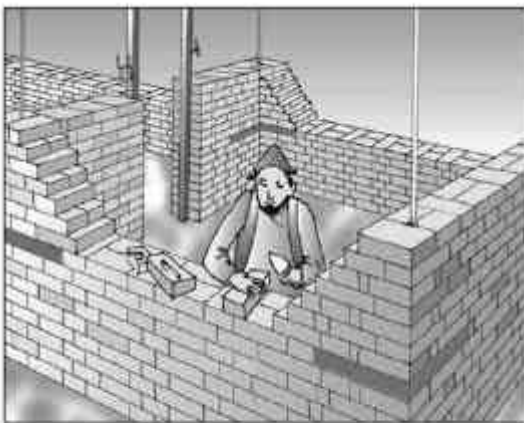

Lay the walls straight in plumb and in right angle. Make steps as shown in picture and then fill the middle part.

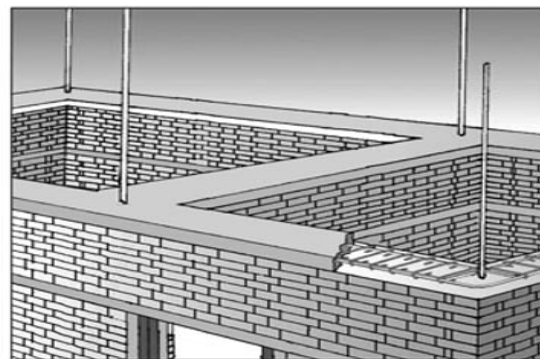

concrete lintel should be laid over the door and window and should cover all wall surface. If floor/roof structure is constructed of timber, also construct a band at floor/roof level.

4.2.1.4. Seismic strengthening measures

Horizontal seismic bands

Horizontal seismic bands should be provided at different levels of a wall. A seismic band should be continuous beam that binds, reinforces and makes all parts of the wall at the

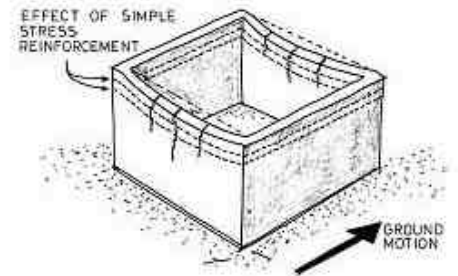
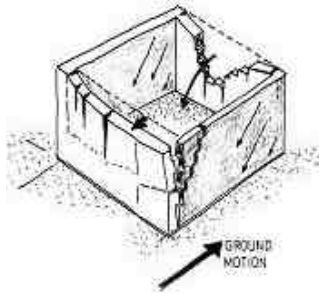

level of the band to act together. The seismic bands should be provided at three levels. These bands should be well bonded together at the corners.

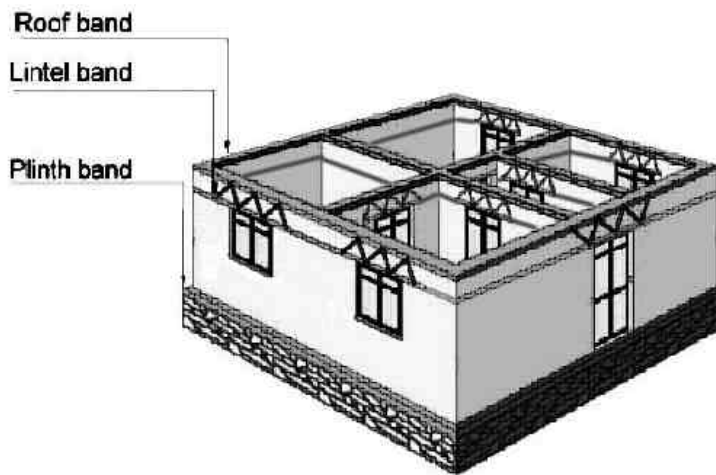

- *Plinth band:* Plinth seismic band is provided at the plinth level. Where a stone plinth or burnt-brick plinth is constructed, a reinforced concrete plinth band may be used. In that case a separate damp proof course will not be necessary. Plinth band is necessary in a building that is resting on soft soil foundation.
- *Lintel band:* Lintel seismic band should be provided at the top level of doors and windows, monolithic with the lintels of doors and windows. The lintel seismic band shall be made of reinforced concrete. When the height of the wall is not more than 2.5 m, the lintel band may be merged with roof band.
- *Roof band:* Roof seismic band or ceiling seismic band should be provided just below the roof. This reinforced concrete band will also serve as wall plate for supporting the roof wooden logs or joists, which should be nailed / spiked to this band for ensuring their stability during earthquakes.

Details of horizontal seismic bands at plinth/lintel and roof level

The horizontal seismic bands in stone/concrete block or brick masonry walls should be provided using R.C.C 1:2:4 as under:

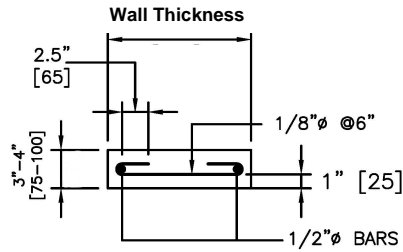

Seismic Band

Details at Corners and T-junctions for Seismic Bands:

The following pattern of steel bars shall be adopted at corners and T-junctions for seismic bands. Seismic bands at the corners and T-junctions must be provided with the following details:

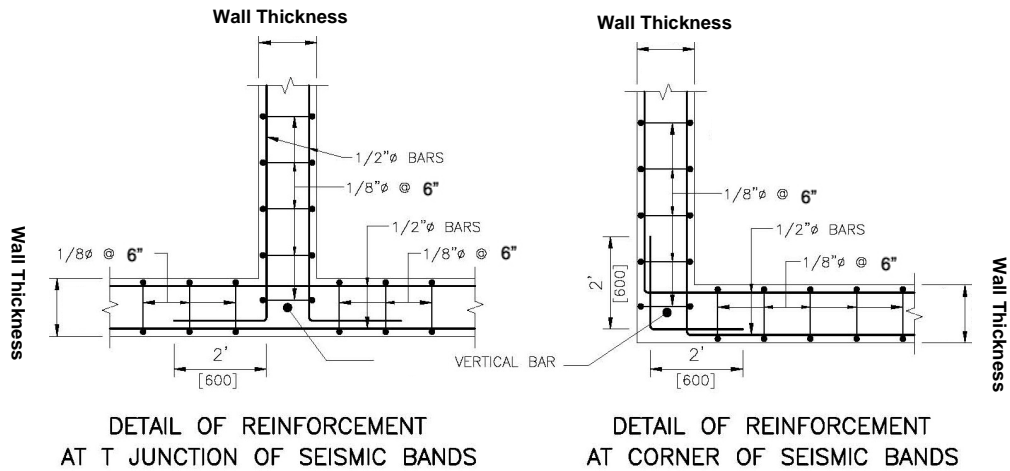

DETAIL OF REINFORCEMENT AT T JUNCTION OF SEISMIC BANDS

DETAIL OF REINFORCEMENT AT CORNER OF SEISMIC BANDS

In addition to horizontal seismic bands steel dowels shall be placed at corners and junctions at a vertical spacing of 18” to 24”. The dowels shall comprise 2 Nos. 3/8” ϕ , 3ft - 4 ft (900-1200) long steel bars with 1/8” ϕ ties at 6” apart. Expanded metal mesh may also be used in place of steel bars and ties. If room sizes are small, dowel bars may be made continuous

Vertical wall reinforcements

Vertical reinforcement, in the form of 5/8" F or min. 1/2" F bars for brick and concrete block masonry and 3/4" F or min 5/8" F bars for stone masonry, shall be provided at corners, junctions and around large openings. Details for incorporating these bars in the masonry are shown in the following figures.

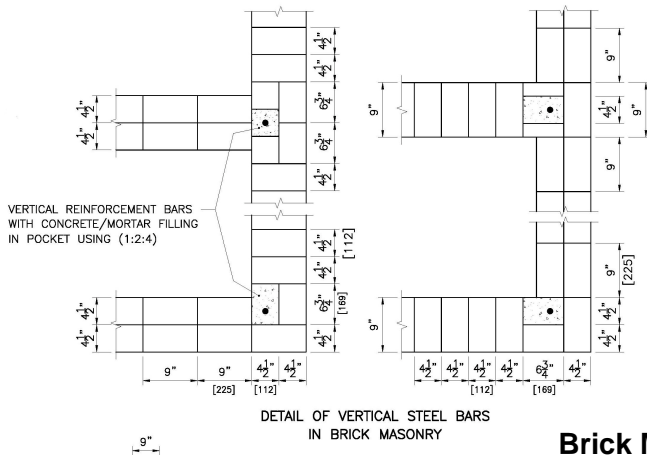
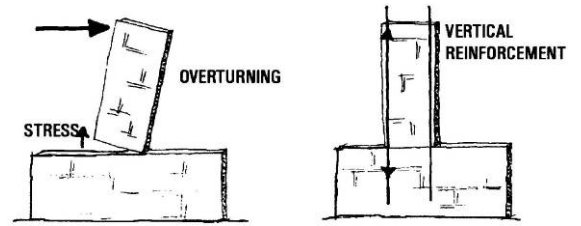

Brick Masonry Wall

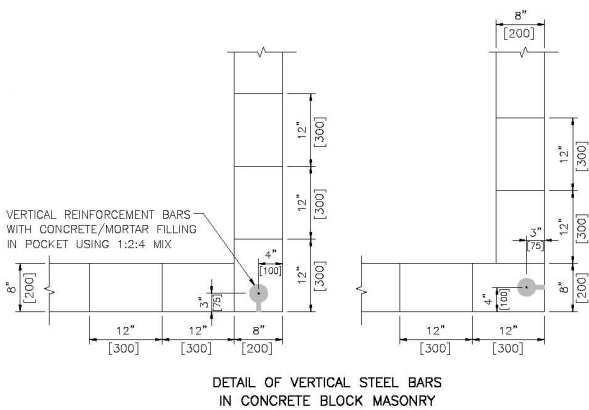
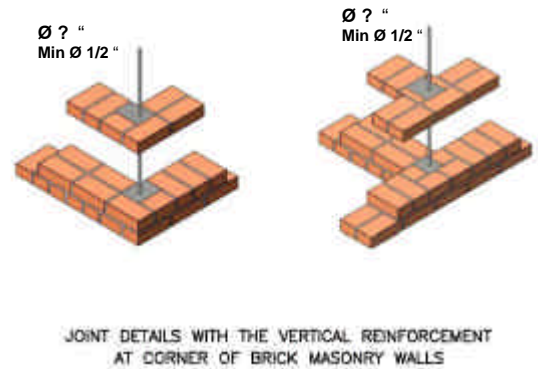

Concrete Block Masonry

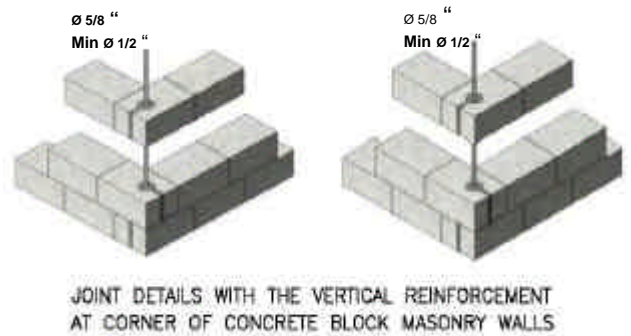

4.2.2. Stones

The stone should be hard and regular. All stones shall be free from defects that will adversely affect the integrity in use and also shall be free from face defects which will be visible in the completed work. Stone for carving shall be especially selected and consistent in grain and color throughout.

4.2.2.1. Factors to be considered for the construction



Lay the wall straight in plumb and in right angles. Avoid vertical joints in one plane. Avoid round and small pieces of stones.

To strengthen connection between walls, either use large stones or concrete or Also employ vertical steel from very foundation to roof band at each corners and T-junctions.

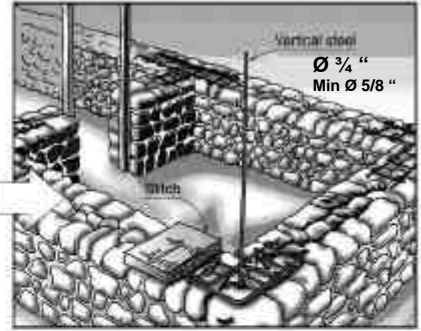

Place Through stones after wall lift of every 600mm at spacing of 1200mm. For through stones even steel bars of S-shape could be used.



To tie-up all the walls together construct bands at sill, intel levels. If floor/roof is constructed of timber, also provide band at floor/eaves level.

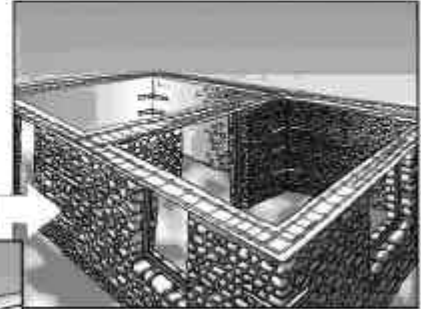

If floor/roof is constructed of timber, tie floor joist/roof rafter with the bands.

4.2.2.2. Through Stones

To reinforce the stone masonry wall, through stone of full length equal to wall thickness should be used every 2' (600mm) lift and be not more than 4' (1200mm) apart horizontally, placed in staggered position.

A through stone could be a stone, concrete block or an S-shaped steel bar of minimum 1/4" ø well packed with mortar.

4.2.3. Concrete blocks

4.2.3.1. Concrete mix

In non-engineered construction, the proportions of concrete mix for concrete blocks are usually kept 1:3:6 by volume of cement : sand : aggregate.



Do not use concrete mix in proportion more than 1:3:6 (cement: sand: aggregate)

The aggregate may be in the form of crushed stone, of maximum 20-mm size. It will be best to make the concrete mixture using whole bags of cement.



Use concrete mortars or wall mortar within 45 minutes of mixing. Use water as less as possible.

Where mixing is done manually without using a power driven mixer, it should be done on an impervious platform, say, using iron sheets or cemented floor. For making a concrete mix:

- aggregates should first be measured and flattened on the platform;
- then sand should be spread on the aggregate;
- and finally cement opened on top.

The material should first be mixed thoroughly in dry state so as to obtain uniform color and then water be added. The quantity of water should be enough to make a soft ball of the mixed concrete in hand.

A little wetter mix is better for hand compaction and drier mix where vibrator is used for compaction.

4.2.3.2. Recommended concrete block

- Solid concrete blocks of nominal size 300 X 200 X 150 mm be used.
- Concrete blocks shall be manufactured using 1:3:6 mix.
- Concrete block with key shall be used for placing the reinforcement.

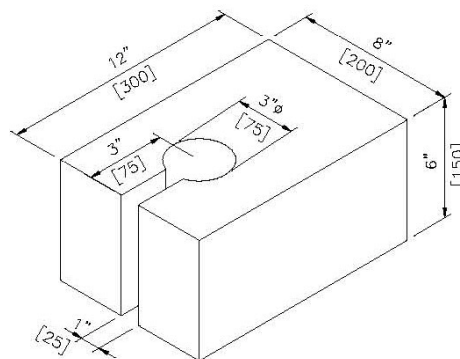

ISOMETRIC VIEW OF CONCRETE BLOCK

Since a cavity formation in solid block walls is not feasible, special concrete blocks with one hole are cast and used at the bar-points. To avoid rising of the hollow blocks high for enclosing the bar in a hollow, slit is made in the wall of the hollow while casting the block.

4.2.3.3. Curing of concrete

Concrete work requires water-curing for a minimum of 14 days so as to gain its strength, otherwise the gain of strength is low and concrete becomes brittle.

Concrete slabs may be kept under water by ponding of water over it by making earthen barriers around the edges.

Columns should be kept covered with wet empty gunny bags. Keeping the side forms intact on the beam webs will prevent the evaporation of water from the concrete and help in curing.

Covering any concrete surface with polythene sheets after wetting the surface will help retain the moisture.

4.3. Openings

4.3.1. Openings in wall

Appropriate openings

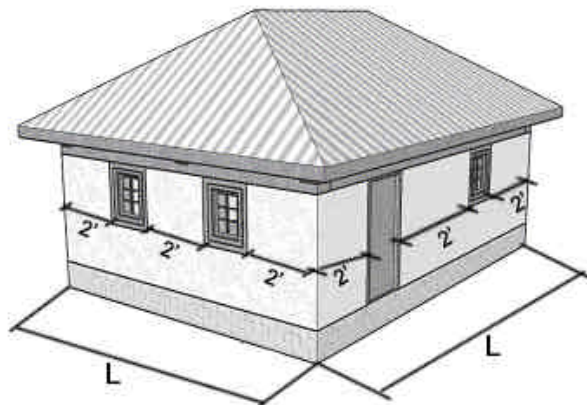

Inappropriate openings



- Openings in the wall are necessary for providing doors and windows.
- But larger and number of openings make the wall weak. Therefore the number and size of openings should be limited.
- The width of an opening should preferably not be more than 1.2m.
- Distance between an exterior corner of the building and the opening should not be less than 2 ft (600 mm).
- Gap between two openings: Wall length between any two openings (doors and/or windows) should not be less than 2 ft.
- The sum of the width of openings in a wall should not exceed 50% of the total wall length.

4.3.2. Lintels

- The lintel takes the load of the part of the wall above the lintel and transfers the load on to the part of the wall on both sides of the opening.
- The lintel transfers the load through the bearing area of the lintel.
- The bearing area of the lintel should be sufficient so that the load is transferred to the wall without unduly stressing the wall.
- Lintel bands should be provided at the top level of doors and windows, monolithic with the lintels of doors and windows.
- Keep lintel level same for doors and windows, In case of window size is more than 3 ft (900mm), provide min. 6" lintel above the window.

4.4. Roof

The structure and cover behave like a diaphragm (rigid and flexible) which resists flexion and breaking. Heavy roof suffers greater seismic forces and may result in severe structural damage or collapse (See figure below). Therefore house in an area prone to earthquakes requires a light roof which distributes its load evenly on the walls. The eaves (projection) also need to be considered part of the wall's protection and should neither be less than 500 mm nor greater than 1m.

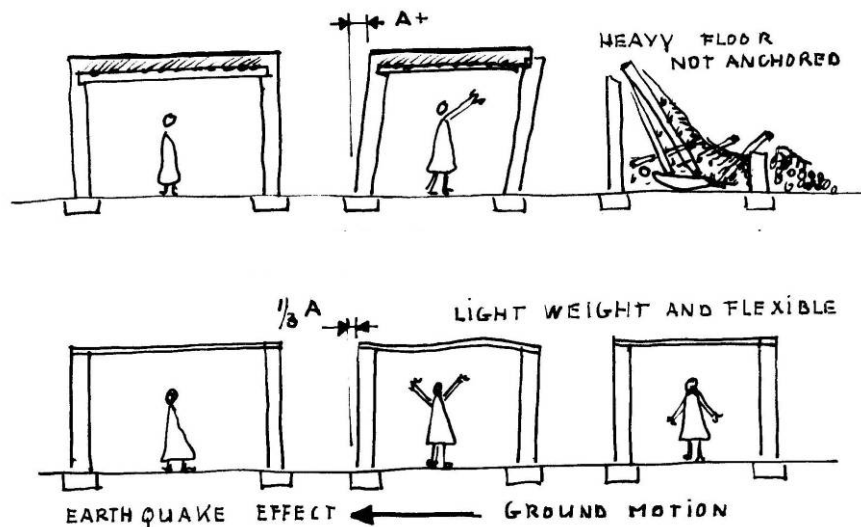

4.4.1. Typical wooden truss

The following figure shows the details of a wooden truss suitable for small spans upto 12 feet or so. Similar details may be adopted for larger span but with larger member sizes.

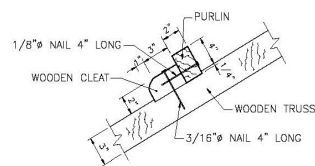
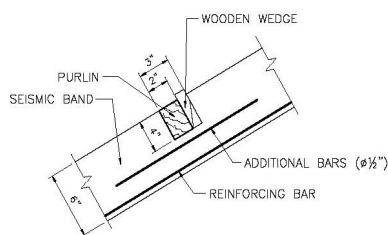
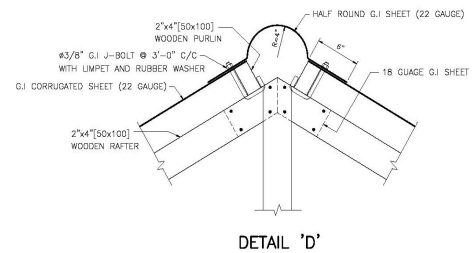
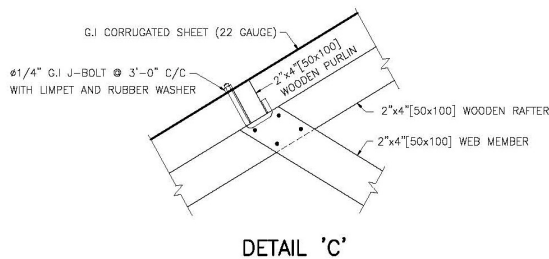
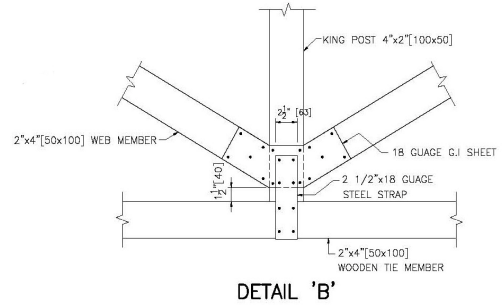
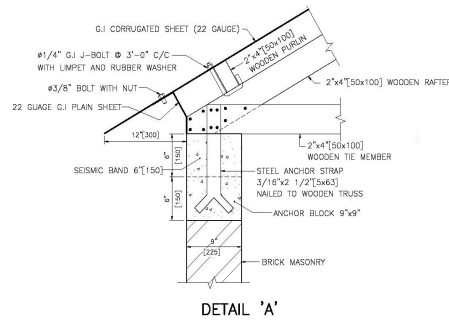
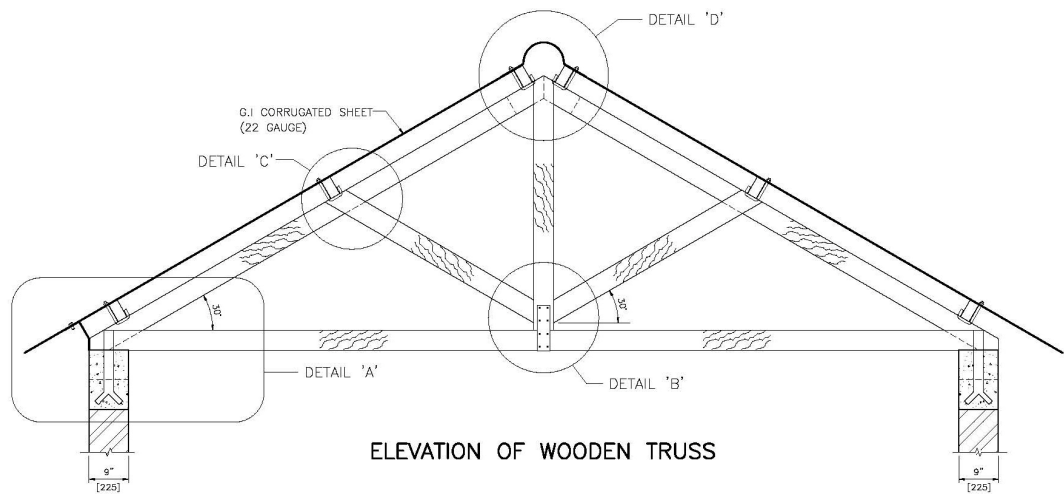

4.5. Plastering and painting

4.5.1. General

The purpose of plastering and painting is to give protection and durability to the walls and the roof, in addition to obvious aesthetic reasons.

The following measures should be adopted for plastering the surfaces:

- All plasters shall have a Cement Sand ratio not less than 1:6.
- The thickness must not be less than 3/8" (10mm).

The exterior of walls after plastering may be suitably painted using a waterproof paint or washed with water solutions of lime or cement or gypsum.

4.5.2. Process

Clean the wall in order to eliminate any loose soil or sand, to guarantee the adherence of the plastering to the wall section. If the wall is wet, you should wait a while so that any water inside the wall can evaporate and be absorbed. Then apply a 10mm layer of plaster.



5. RETROFITTING

The retrofitting is the action taken to upgrade the seismic resistance of an existing building so that it becomes safer against future earthquakes.

This can be in the form of providing seismic bands, eliminating sources of weakness or concentrations of large mass and openings in walls, adding shear walls or strong column points in walls, bracing roofs and floors to be able to act as horizontal diaphragms, adequately connecting roofs to walls and columns and also connecting between walls and foundations.

5.1. Assessment of building damage

The assessment of building damage must be done before carrying out repairs or strengthening

Before commencing any repairs it is important to

- Determine the materials which have been used in the building;
- Carry out a detailed foundation check;
- Carry out a detailed structural assessment of the damaged building with particular attention to vulnerable elements of the structure.

This should be assessed by a qualified structural engineer. It should be noted that both nonstructural and structural repairs might be required to a building. The priority repairs should be to the structural components before embarking on any non- structural repairs (cracked slabs, falling plaster from walls and ceilings, broken parapets etc).

There is absolutely no point carrying out repairs to a building if the foundations have failed or the ground can no longer support the damaged building. Repairs to damaged foundations can be costly and difficult to instigate and hence a fine line may exist between demolishing the building or continuing with the repair.

Moreover, the site can become dangerous. In fact, earthquakes may cause failure of soft or loose ground whilst hillsides or sloping ground may become unstable. Whole towns and villages may be affected and although a building may appear safe for repair, near the foot of the slope or on it, further slope failures could be triggered by relatively small aftershocks or another future earthquake. Buildings in such terrain will require specialist advice of the stability of the whole area. No repairs to buildings should take place until this advice has been obtained.

5.2. Foundations

One of the most frequent causes of deterioration of the walls of a house is their direct contact with the ground humid thus making them vulnerable in the event of an earthquake.

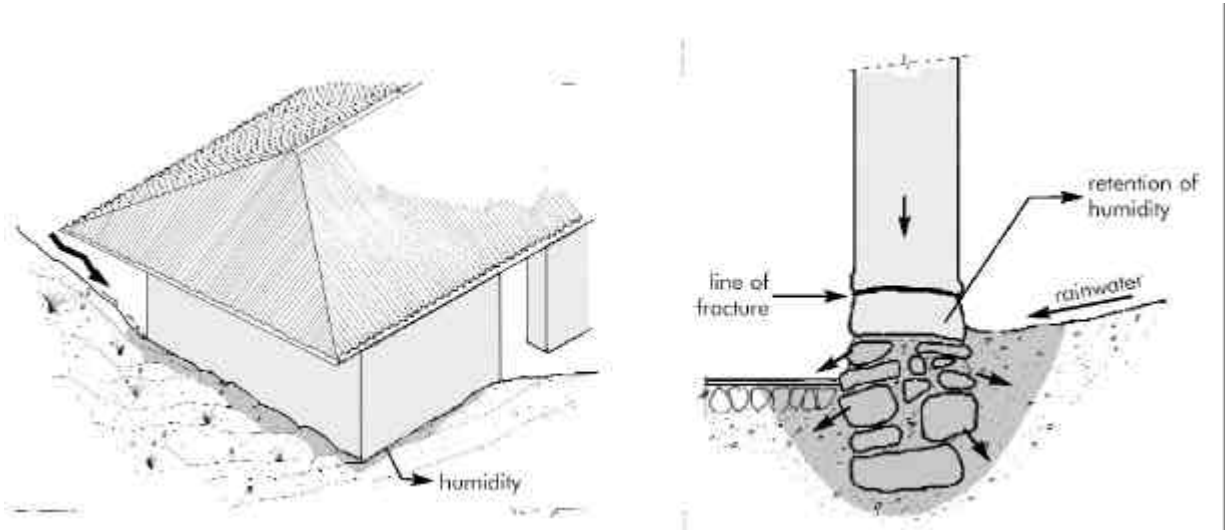

Example: ground sloping towards the wall, unstable and poor quality foundations and wall bases, prone to settling due to the effect of humidity and the inferior quality of the ground.

5.2.1. Alternative 1: Cleaning & Drainage

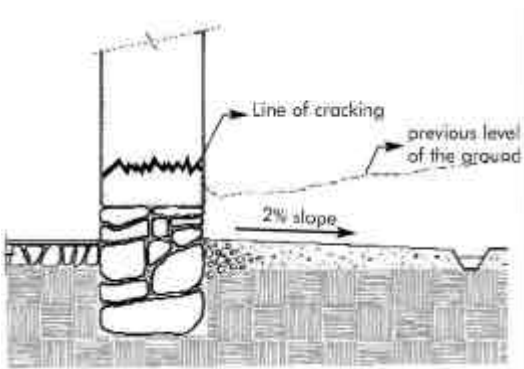

If after an earthquake the wall has cracks in certain sections and the bricks are in a satisfactory state we must eliminate the earth which covers the wall base, and level out the ground a minimum of 100mm below the wall base.

5.2.2. Alternative 2: Demolition & Reconstruction



If after an earthquake the base of the wall has become loose, if there are cracks in the entire wall and sinking which makes the wall unstable and dangerous, we must then: Dismantle it after propping it up and build a new wall from the foundations.

5.3. Walls

After an earthquake, if a wall has become out of plumb by more than 2% per meter, then it will need to be dismantled or completely demolished since this deformation makes the wall lose its load carrying capacity. To do this you will need to dismantle the wall after having checked the stability of the roof as described above.

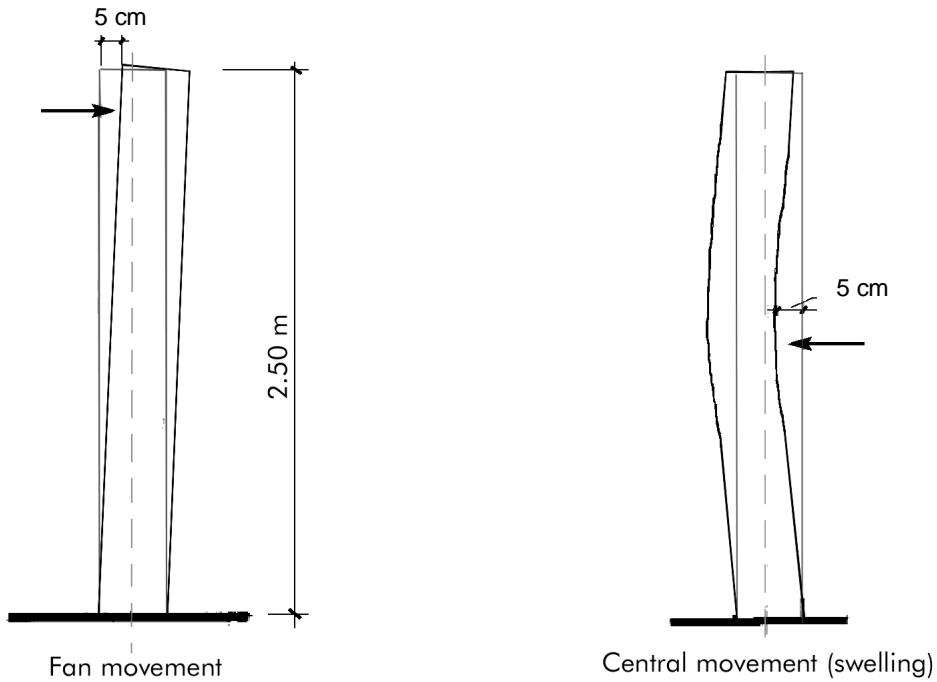

If the out of plumb is less than 1% and the walls do not show any signs of damage or diagonal cracks which cross it completely, the affected parts can be repaired.

5.3.1. Bricks walls

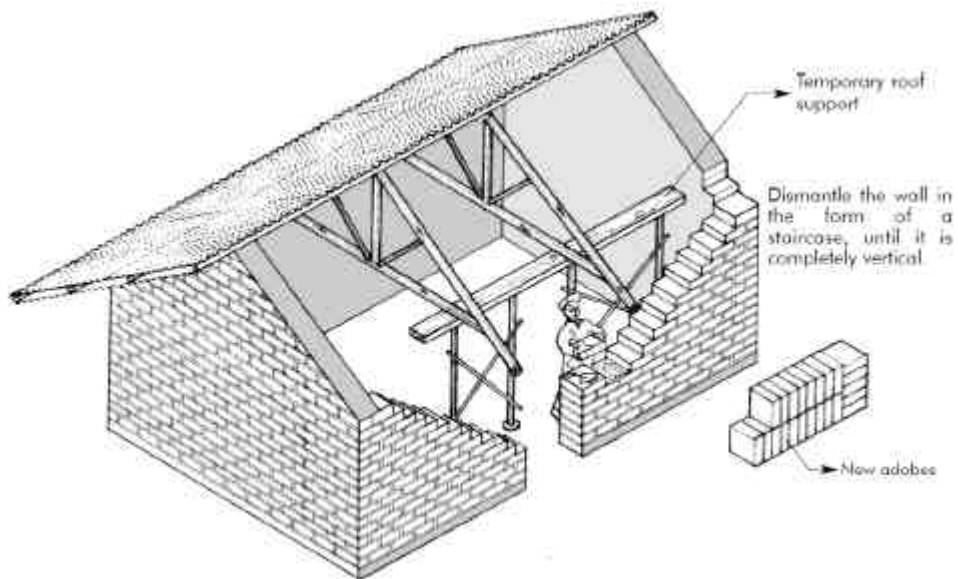

5.3.2. Gable wall

5.3.2.1. Repair the gable

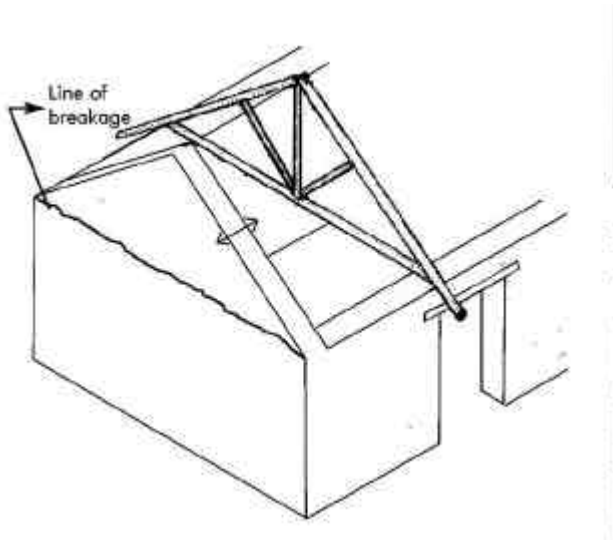

Cracks in gabled walls are frequent after earthquakes because generally they are free-standing without braces.

If during the assessment we observe that the gable is broken but stable and vertical, then we can repair and reinforce it with keys placed at a right angle to the line of breakage. We can also repair it with the wire mesh on entire wall with plaster on both sides in properly fixed and secure position.

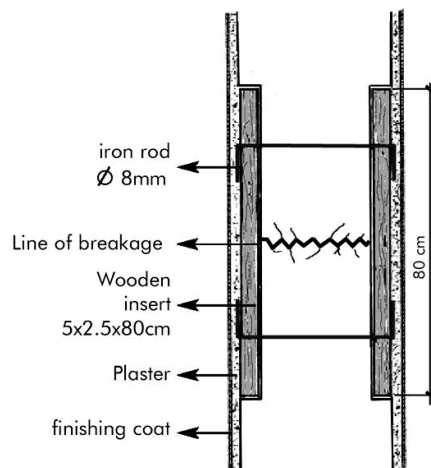
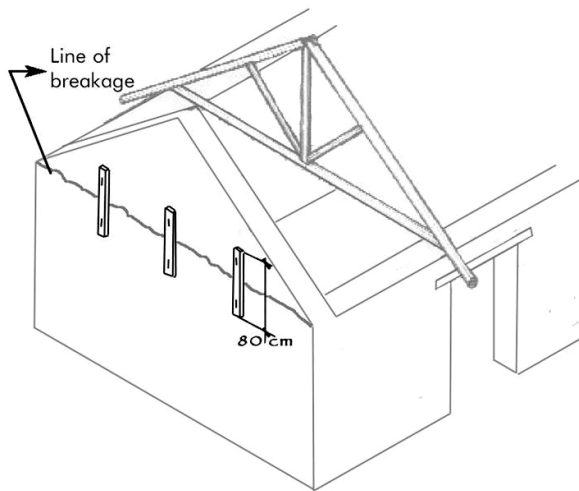

It is better to make holes in the mortar joints, to avoid damaging the adobes.

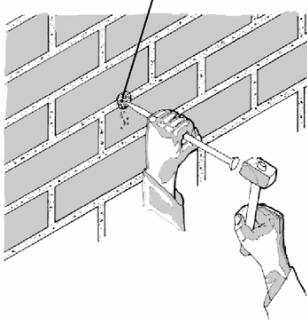

In the case of a bricks wall, to fit the keys it is advisable to drill the wall to make 5 cm diameter holes to fit the construction irons embedded in the cement mortar.

5.3.2.2. Lightened Gable

If the earthquake has caused serious damage in the gabled wall and part of it has collapsed, then it is advisable to dismantle it and change it to a frame, making it more resistant in the event of an earthquake.

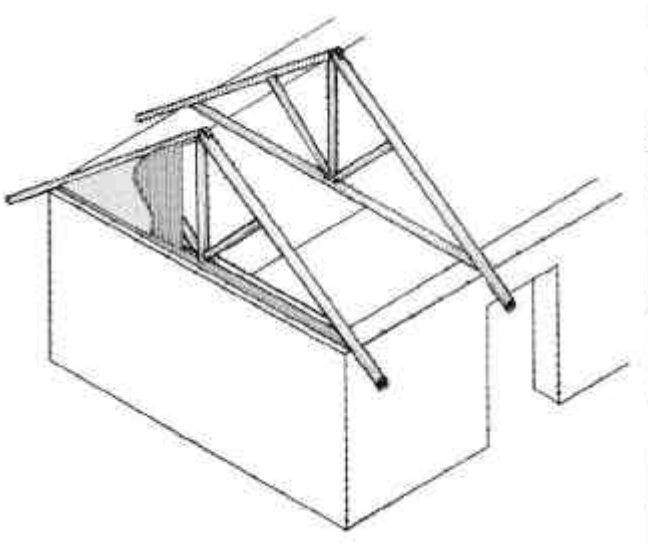

5.3.3. Wall corner

5.3.3.1. Reinforcement with Wire Mesh

Corner joints tend to be weak areas in the event of an earthquake, especially when they do not have correct bonding.

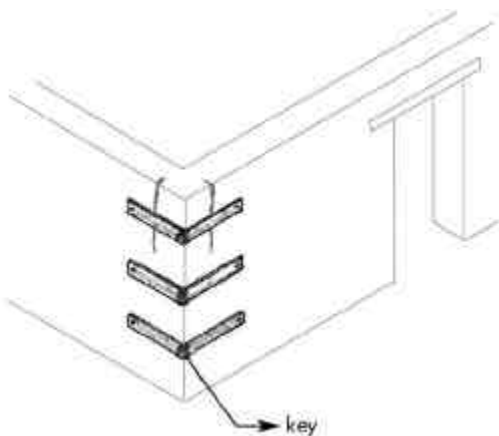
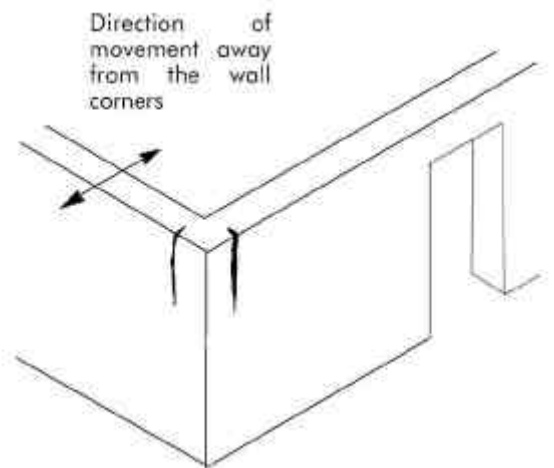

If the cracks are not serious and there is no loosening, then they can be repaired by fitting keys. It is advisable to fit them at 5 row intervals taking advantage of the mortar joints. Afterwards cover any remaining spaces between the key and the wall with cement mortar. They can be repaired by the wire mesh on the entire wall with plaster on both sides in properly fixed and secure position.

5.3.3.2. Dismantling and Reconstruction

This part has been illustrated with brick wall, however, it is correct also for stone wall

When the walls have suffered greater damage, like collapsed sections, a more delicate operation is needed.

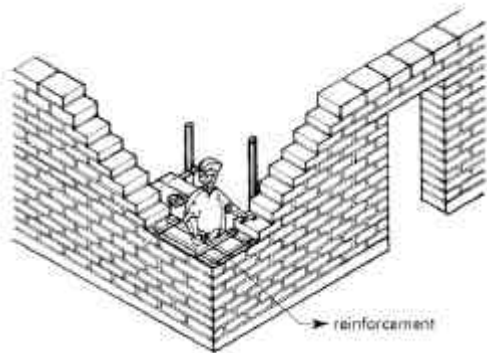

First dismantle the wall in the form of a "staircase" on both sides, and then rebuild the wall with new bricks or stones. In order to avoid this happening again, reinforce the wall with the details of corner with the steel reinforcement shown above.

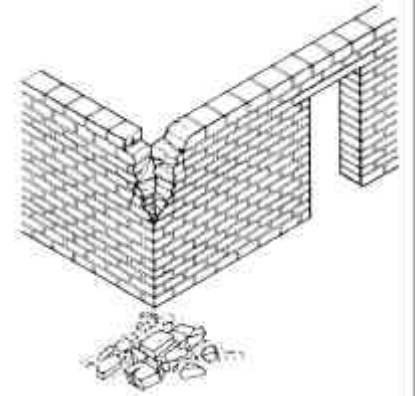

5.4. Roof

After an earthquake, there will be cracks in the part which supports the load of the roof, mainly when the ring beam which distributes the load horizontally is missing.

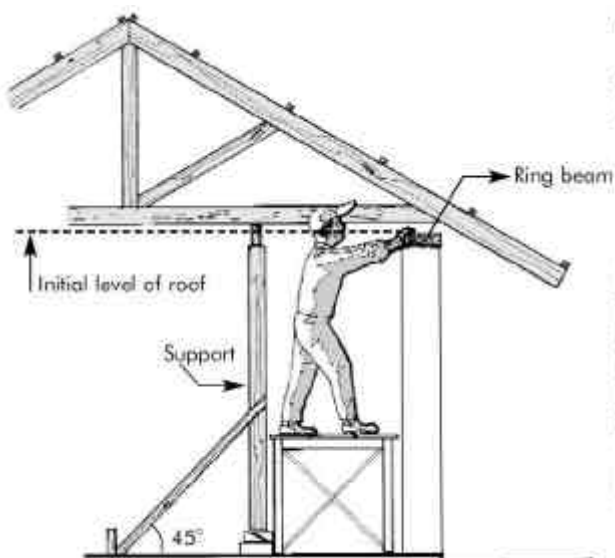
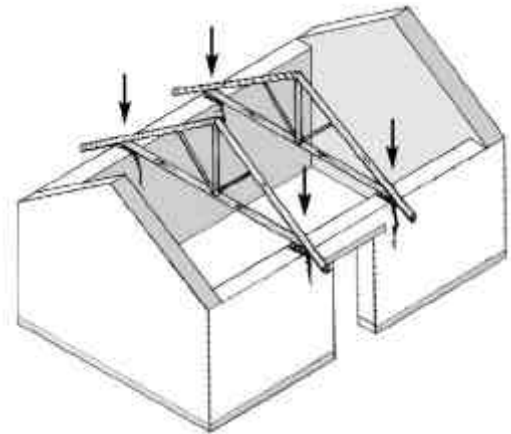

Once the roof has been supported, the damaged adobes are eliminated and replaced with a ring beam or a wall plate (made from cement). Afterwards the roof structure will return to its initial position.

References

“Standard Design of Houses in Earthquake Affected Areas”, by National Engineering Services Pakistan (Pvt.) Ltd. NESPAK, April 2006

“Earthquake Resistant Measures for Small Buildings” earthquake Affected Area Reconstruction and Rehabilitation Project, Ministry of Housing and Physical Planning, 1989

“Guidelines for Earthquake Resistant Construction: Low Strength Masonry” Ministry of Housing and Physical Planning of Nepal, Kathmandu, Nepal, April, 1994

UNCRD, 2003. “Guidelines for Earthquake Resistant Design, Construction, and Retrofitting of Buildings in Afghanistan”, Afghanistan Ministry of Urban Development (MUDH) and Housing, United Nations Centre for Regional Development (UNCRD), June 2003.

NSET & ADPC, 2005. “Earthquake Resistant Construction of Buildings Curriculum for Mason Training – Guidelines for Training Instructors”, National Society for Earthquake Technology, Nepal; Asian Disaster Preparedness Centre, February 2005.

ADPC, 2002, “Living with Earthquakes”. “Guidelines for Earthquake Resistant Non-Engineered Construction”, The International Association for Earthquake Engineering.

ADPC, 2002, “Regional Workshop on Best Practices in Disaster Mitigation”, Indonesia, September 2002.

UN-HABITAT, 2005, “Guidelines for Earthquake Resistant Construction of Non-Engineered Rural and Suburban Houses in Afghanistan, July, 2005

Guideline for earthquake resistant non-engineered construction from the National Information Center of Earthquake Engineering (KAMPUR) and the International Association for Earthquake Engineering

Indian Institute of Technology Kampur Earthquake Tip from

Flyers and guideline from the National Society for Earthquake Technology (NEPAL)

Anti-seismic construction handbook from CRAterre

Aga Khan Planning and Building Services, Pakistan (AKPBS,P), BACIP, “Galvanised Wire-Mesh Wall Reinforcement Methodology”, “The Development of the Wire-Mesh Knotting Equipment”, “BACIP Galvanised Wire-Mesh Wall Reinforcement”, “Development of the BACIP Wire-Mesh Knotting Equipment”, “BACIP, Insulation advice table”
Made by Sjoerd Nienhuys, December 1999

Earthquake resistant reconstruction and new construction of masonry building in Jammu and Kashmir state made by Professor Anand S. Arya.

Nepal building code

UNDP DRM Program, “Guidelines for earthquake resistant reconstruction and new construction of masonry buildings in Jammu & Kashmir state”, oct. 2005, Prof. Anand S. Arya National seismic Advisor.

IAEE, NICEE, “Guidelines for earthquake resistant non-engineered construction”, 2004
Modular Gabion System